

How to optimize data transmission via Magic



devolo Magic adapters are designed for a stable and strong data transmission in your home. In rare cases, however, low transfer rates occur at individual sockets in your home. This is why we would like to show you how you can optimize the transfer between the adapters in three simple steps.

Info:

Some electrical devices return an interference voltage to the power grid and thus possibly influence the data transmission via the power grid. These are, for example, power supplies of other devices and lamp controllers (dimmers). The following rule applies here: The longer the distance between the electrical interferer and the adapter, the smaller its influence is ultimately. If the interferer is plugged into an adjacent socket, this may be particularly disadvantageous for the data transmission.

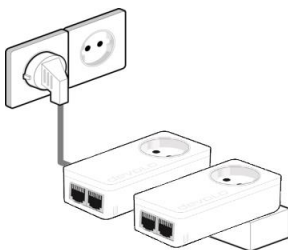
1. Check the connection



A simple way to check if both adapters are connected is to plug both adapters side by side into a power strip. Now connect the power strip to the mains. If both adapters form a network, the PLC-LED (depending on the product in use  or ) will light up permanently white.

If this is not the case, the devices must be paired with each other. Please proceed as described in the respective manual. If you no longer have this manual, you can download it from our website:

<https://www.devolo.com/support/downloads>

2. Positioning the adapter properly

Now plug the adapters into the sockets in which you want to use the devices. Here are a few basic rules for ideal positioning:

- If possible, plug the adapters directly into a wall socket and not into a socket strip or an extension cable.
- If there are several sockets directly next to each other in the wall, they behave like a socket strip. Single sockets are ideal.
- If other devices in the immediate vicinity are to be supplied with power, we recommend adapters with an integrated socket. Plug the other devices directly or via a socket strip into the socket of the adapter.

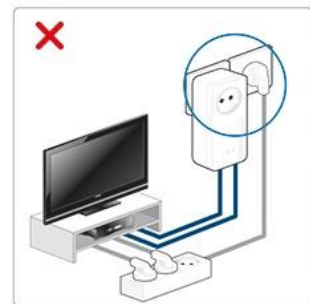
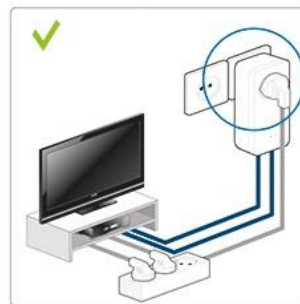
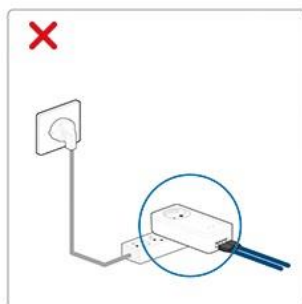

3. Identify source of interference

If the data rate is not satisfactory even after ideal positioning, an electrical device in the vicinity could be the cause of the interference. For testing purposes, switch off all electrical devices in the vicinity one after the other (if possible, disconnect them from the power supply) and use the LED display or, preferably, our "devolo Cockpit" software to check whether the transfer rate is improving. Power supplies in devices, dimmers of lamps or chargers are often the cause of interference. If the source of the interference is found, select a different socket for this device or plug it into the built-in socket of the adapter (if available).

Info:

If the PLC-LED lights up white permanently, you have established a good connection. If the LED lights up white and flashes red briefly, the connection is not optimal. You can check the exact transmission rate using the "devolo Cockpit" software.

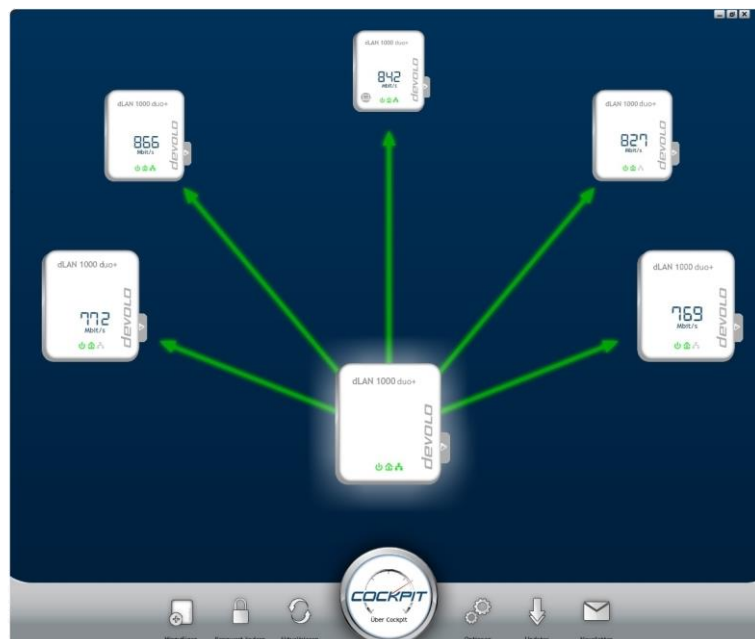

The current version of the software can be downloaded free of charge from the following link:

<https://www.devolo.com/internet-in-any-room/devolo-cockpit>

© devolo AG

While the information in this manual has been compiled with great care, it may not be deemed an assurance of product characteristics.

devolo shall be liable only to the degree specified in the terms of sale and delivery.

The reproduction and distribution of the documentation and software supplied with this product and the use of its contents is subject to written authorisation from devolo. We reserve the right to make any alterations that arise as the result of technical development.

Brand

Wi-Fi®, Wi-Fi Protected Access™, WPA™, WPA2™ and Wi-Fi Protected Setup™ are registered trademarks of the Wi-Fi Alliance®.

devolo, dLAN®, Vianect® and the devolo logo are registered trademarks of devolo AG.

devolo AG

Charlottenburger Allee 67

52068 Aachen

Deutschland

www.devolo.de

Aachen, August 2019